

CHILDREN'S ELECTRIC R/C CAR

A300 Licensed Audi R8 Spyder

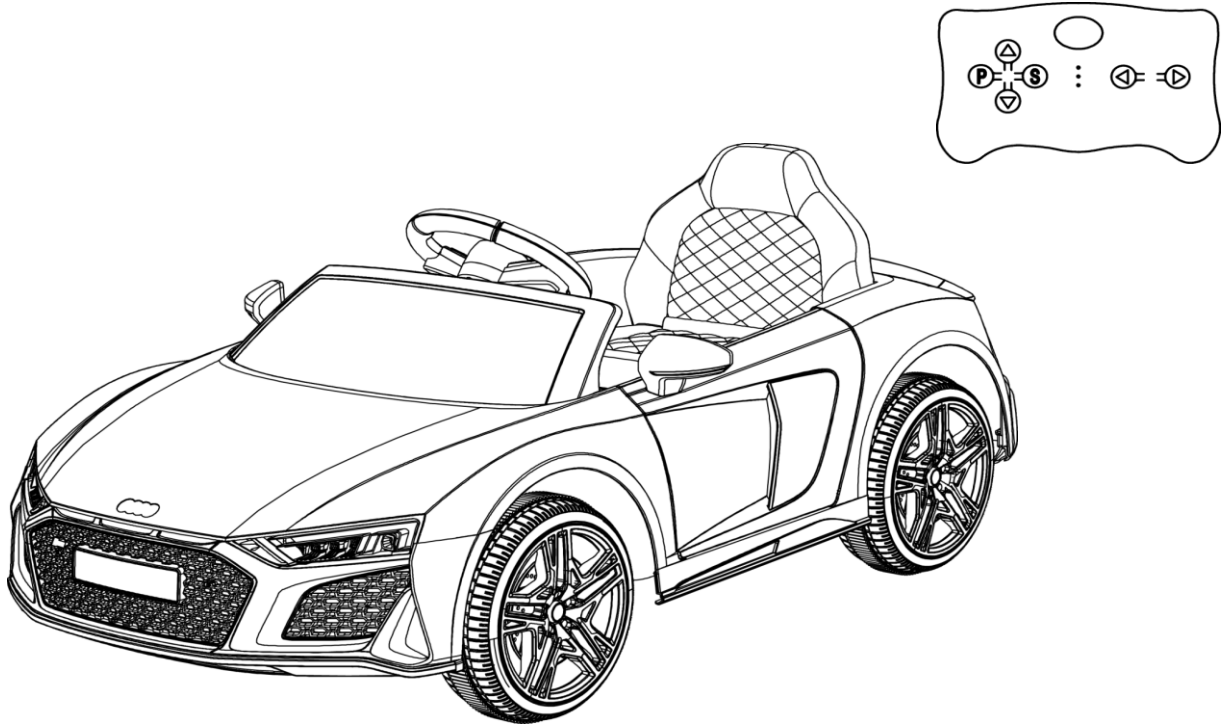

Illustration used as a reference only. Instructions apply to various models.

Failure to follow instructions may result in injury, property damage and will void warranty.



**BATTERY MAY BE PARTIALLY CHARGED ON DELIVERY.
IT IS CRITICAL FOR THE BATTERY TO BE FULLY CHARGED PRIOR TO USE
(8-12 hours).**

Important Information

Important	Warning!
Age: 3 Years + Maximum user weight: 30kg	1. For domestic use only 2. Not to be used in traffic 3. Adult assembly required

Important - Please read these instructions in full before assembly or use

These instructions contain important information which will help you get the best from your product and ensure safe and correct assembly, use and maintenance.

CAUTION:

- **Product is to be used strictly under appropriate adult supervision. Children are not to be left unsupervised with the product.**
- **Product is suitable for children aged 3+ and up to a maximum weight capacity of 30kgs. Overloading the car may result in damage to integral parts such as motor and gearbox and will void all warranty.**
- **Supplied seatbelt is a decoration only and is only intended to instill a sense of practicing safety in children. It does not provide any substantial protection and not to be relied on for the purpose of safety.**
- Please ensure an adult visually inspects the product prior to each use, for any signs of wear and tear and damage. If any abnormal damage or cracks are exhibited, please cease using the toy immediately, as it may be unsafe.
- The product should not be used on public streets or roads, near moving vehicles, steep inclines/hills or near pools or water, or any other dangerous environment.
- Do not expose the product to liquids or harsh detergents. Clean only with a soft, clean cloth to avoid causing damage to the surface of the product.
- Product is designed to be used on a suitable, flat, debris free surface. Please do not use the product on sand, gravel, dirt, grass and uneven or rough surfaces.
- Using the product indoors may result in damage to flooring.
- Product is equipped with a remote control which is to be used only by responsible adults.
- Replace batteries in the remote control if the operating range is reduced.
- Only switch between reverse and forward modes when the car is stationary. Don't suddenly switch between forward and reverse directions whilst the car is moving, as it will likely damage

the product.

- This product is equipped with motors which can produce sparks. Please keep away from flammable products.
- Supplied packaging is not a toy and is to be disposed of thoughtfully.
- Adult supervisors are expected to read the supplied instructions in their entirety and provide correct guidance to children. Instructions should cover such basic elements as:
 - Correctly steering, starting and stopping the toy car;
 - Only a single rider is to use the product at any given time;
 - Shoes to be worn at all times;
 - All parts of users' bodies and their clothing to be kept away from moving parts failing which they run a risk of friction burns/and or risk of entrapment.
- Product is equipped with an overheat/overload function. This function is self-resetting to avoid overheating and damage to the product should the product be overloaded. Once the fuse has been tripped, it will auto-reset itself after approximately 10 seconds which will then allow the toy car to resume normal operations. To avoid repeatedly tripping this function do not overload the toy and be within the weight limit and do not drive the toy car in an inappropriate manner and conditions.

Charging the Battery

- All charging and re-charging must be carried out by an adult.
- Do not attempt to use the product while it is being charged.
- Charging should be carried out under cover and in a well-ventilated area.
- Always ensure the charger is switched off before connecting it to the product/battery.
- Always ensure the charger is plugged into a wall outlet. Do not use an extension.
- Do not charge near sources of potential sparks, fires or flames or where flammable gases, liquids and materials are stored.
- During charging the battery and the charger may get hot.
- Only charge the battery for a maximum time of 8 - 12 hours.
- Do not leave the charger plugged into an outlet or connected to the product/battery once charging is completed.
- Never attempt to recharge a fully charged or partially used battery for an extra boost.
- Do not over-charge as it will significantly shorten battery life.
- Always ensure that once the battery becomes discharged/flat that you re-charge for the recommended time. Failing to do so will significantly shorten battery life.
- Charging the product below 4oC (40oF) or above 40oC (104oF) will decrease the battery life significantly.
- V.R.L.A. batteries are heavy and contain lead & acid. They are dangerous if improperly handled.

- Only use the charger supplied with the product. The use of other chargers may cause damage to the battery and/or cause explosion.
- Battery chargers used with the product are to be regularly examined for damage to the cord, plug, enclosure and other parts, and in the event of such damage, they must not be used until the damage has been repaired.
- Only use the battery supplied with this product. Use of other batteries may cause damage to the motor, charger and wiring, which could lead to fire and/or explosion, and void warranty.
- Dead batteries are to be removed from the toy and disposed off responsibly.
- Always ensure that you connect the battery with the correct polarity.
- Never short-circuit the terminals of the battery, or any subsequent wiring.
- Never bypass or bridge a broken/blown fuse or circuit breaker and always replace with the same type/value and model.
- **BATTERY CYCLE WILL DEplete OVER TIME AND IS REGARDED AS A CONSUMABLE PART COVERED BY 6 MONTHS WARRANTY FROM THE DATE ON INVOICE.**

Parts List

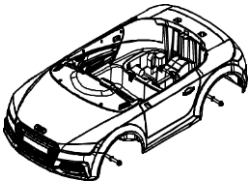
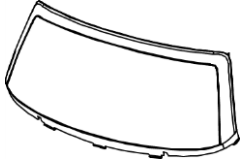
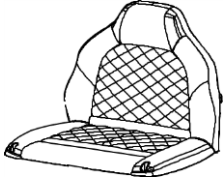
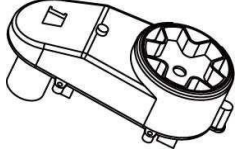
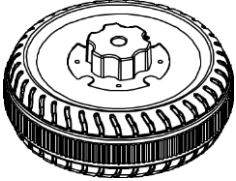
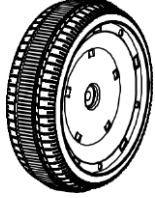
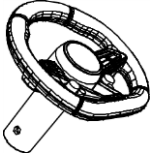
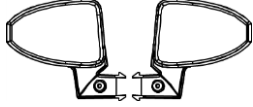
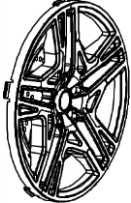
PART NO	PART NAME	PICTURE	Qty		PART NO	PART NAME	PICTURE	Qty	
1	Vehicle body		1		2	Windshield		1	
3	Seat		1		4	Gear box		2	
5	Driving wheel		2		6	Wheel		2	
7	Steering wheel		1		8	Rear view mirror		1 pair	Left & right
9	Wheel hub		4						

#4 Gear box & #5 Driving wheel will be 4pcs for 4X4 version optional.

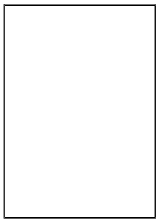
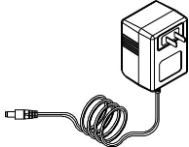
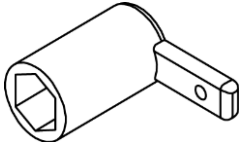
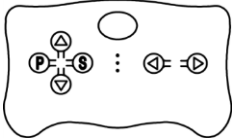
PART NO	PART NAME	PICTURE	Q:ty (pcs)	REMARKS	PART NO	PART NAME	PICTURE	Q:ty	REMARKS
10	Screw		2		11	Instruction manual		1	
12	Charge		1		13	Spanner		2	
14	Remote control		1	Not included AAA1.5V battery					

1	Vehicle body x1	2	Windshield x 1
3	Seat x1	4	Gear box x 2
5	Driving wheel x 2	6	Wheel x 2
7	Steering wheel x 1	8	M10 Washer x 2
9	M8 Washer x 4	10	M8Nut x 4
11	Bolt x 1	12	M5Nut x 1
13	Rear view mirror x 2	14	Wheel hub x 4
15	Screw x 2		

NOTE: Some Parts Shown are assembled on both sides of vehicle

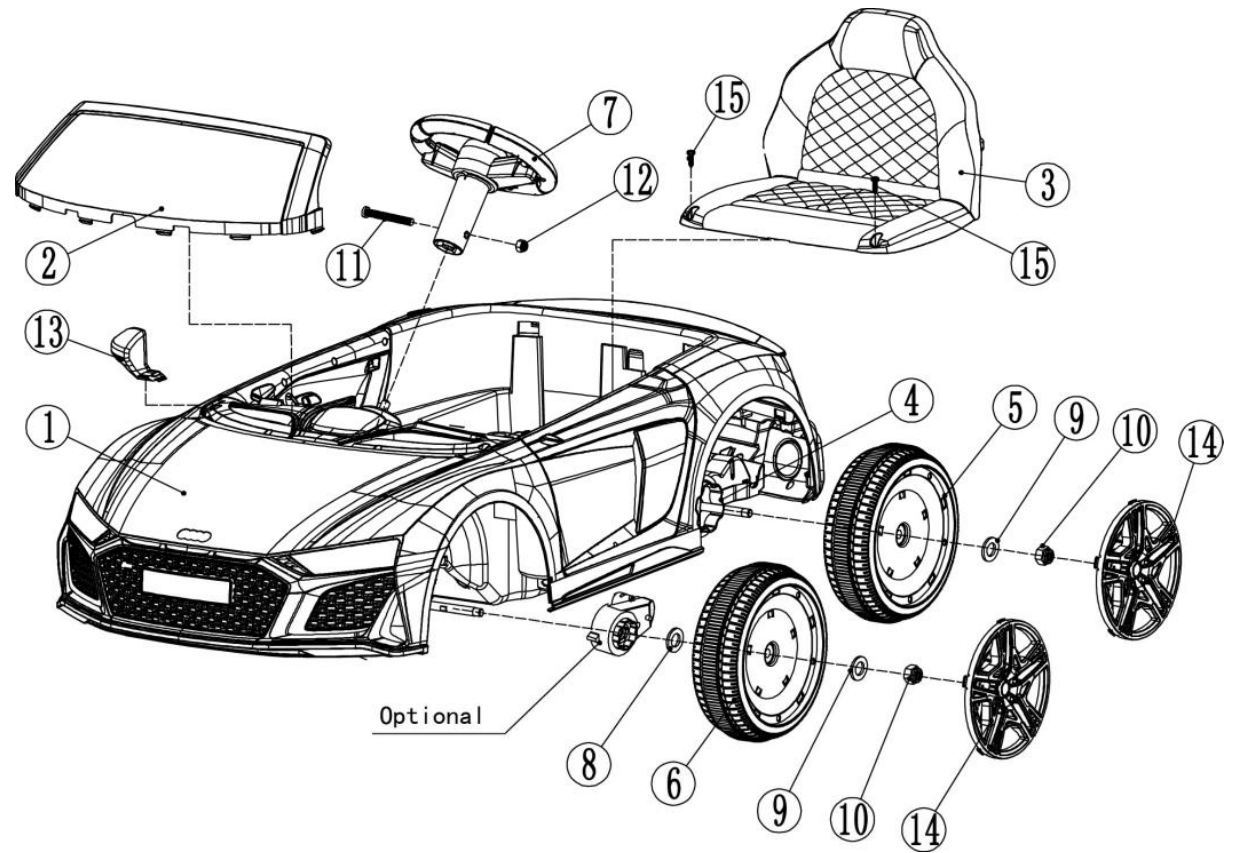

ASSEMBLY

1. Install the rear wheels

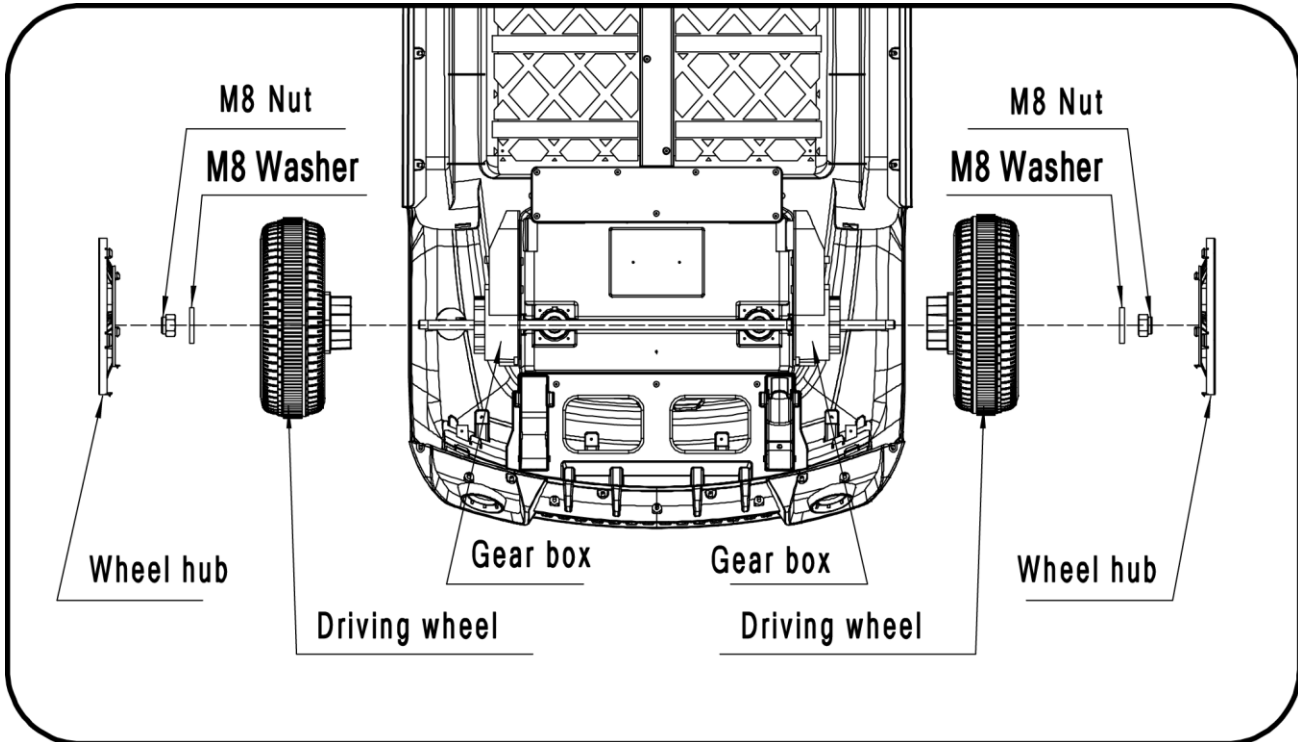

- Put the driving wheel (5) through the rear axle and fix it with washer and nut and wheel hub in turn.
- Repeat the process on the second wheel.

2. Install the front wheels

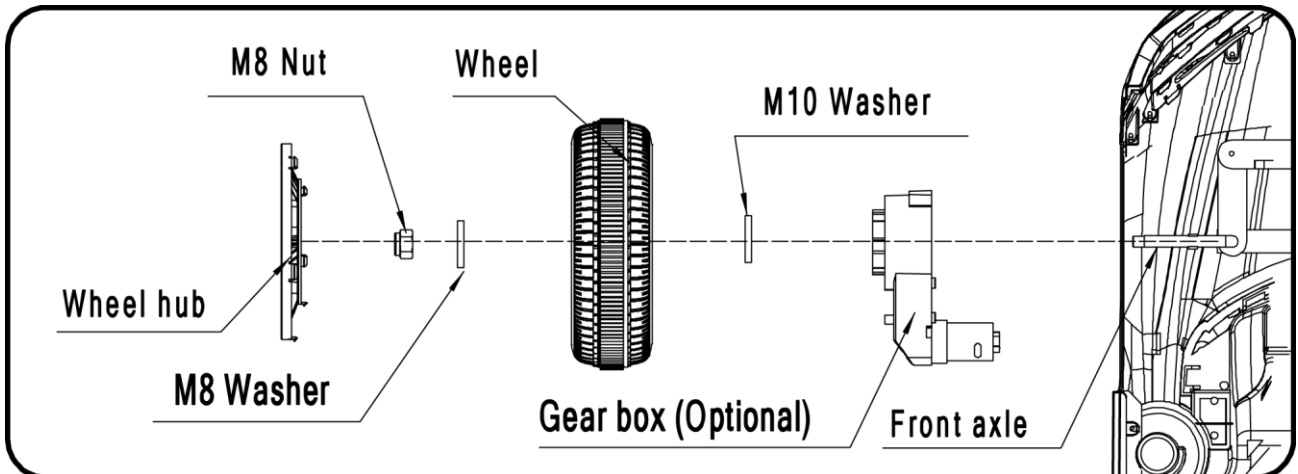

- Remove the nut and washer on the front axle.
- Installing dual drive:
 - Put the washer and wheel through the front axle and fix it with washer and nut and wheel hub in turn.
 - Repeat the process on the second wheel.
- Optional for 4X4 version:
 - Install gear box on the left side, and the wire connector plug.
 - Put the wheel through the front axle and fix it with washer and nut and wheel hub in turn.
 - The other side is same as above.

3. Install the steering wheel

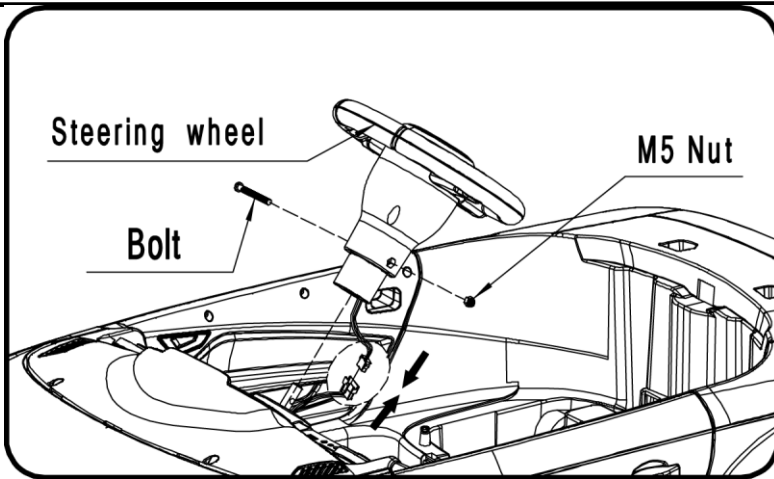

- As shown above, remove the nut and bolt from the steering wheel, connect the steering wheel and dashboard middle connector.
- Install the steering wheel and fasten with nut, and bolt.

4. Connect the power supply

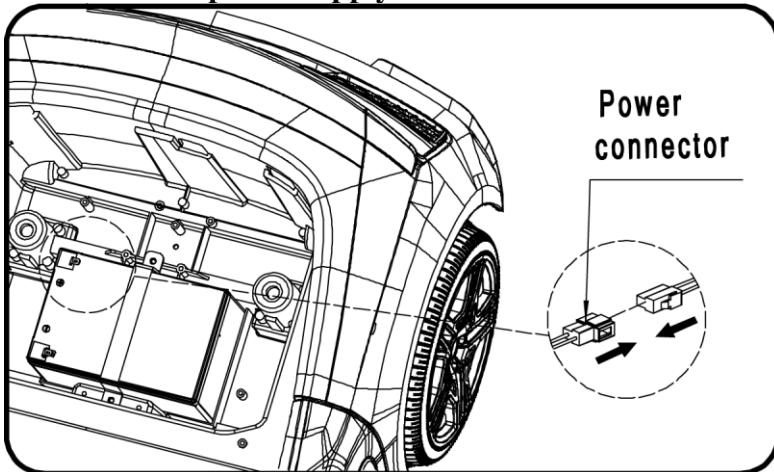

- As shown above, connect the power connectors.

5. Install the seat

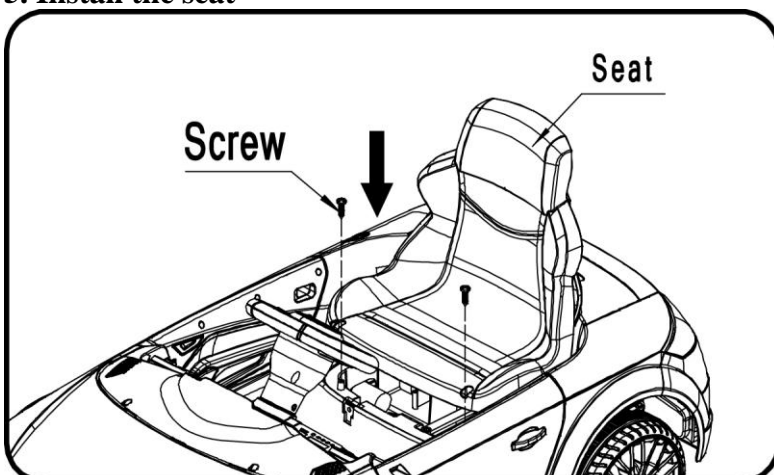

- Install the seat in the corresponding position and fasten with two screws.

6. Install the windshield

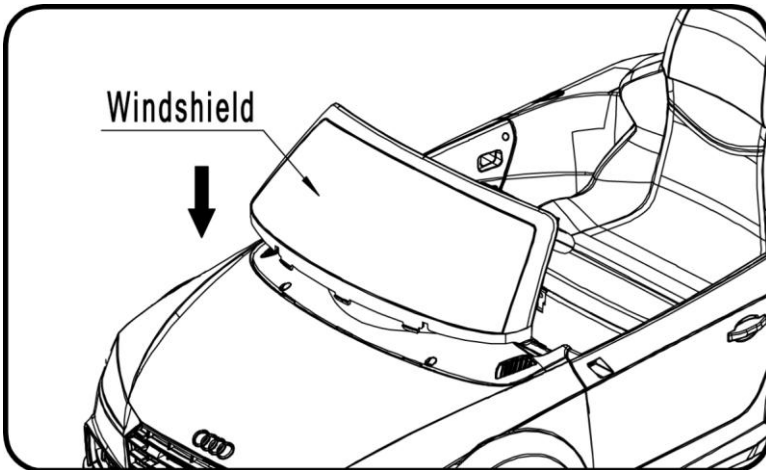

- Press the windshield downward, carefully apply pressure to fix it in place. Ensure pressure applied is not excessive as damaging the windshield will void warranty.

7. Install rearview mirrors

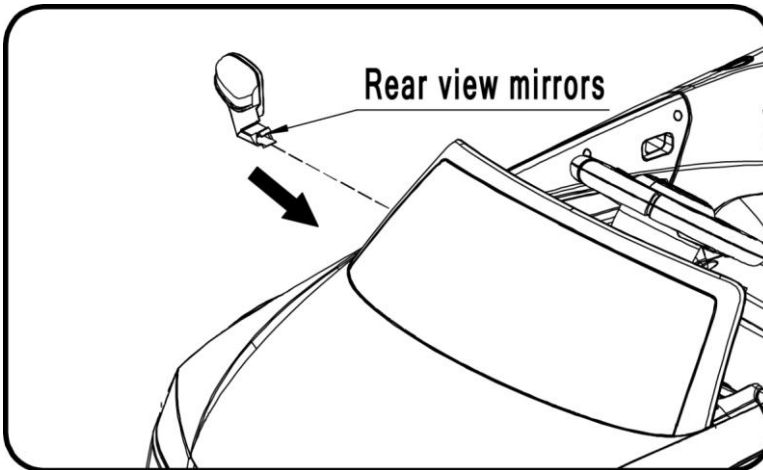

- Insert and push the two rear view mirrors in accordance with directions shown with arrows, to ensure they are in fixed in position. Ensure pressure applied is not excessive as damaging the parts will void warranty.

How to operate your vehicle

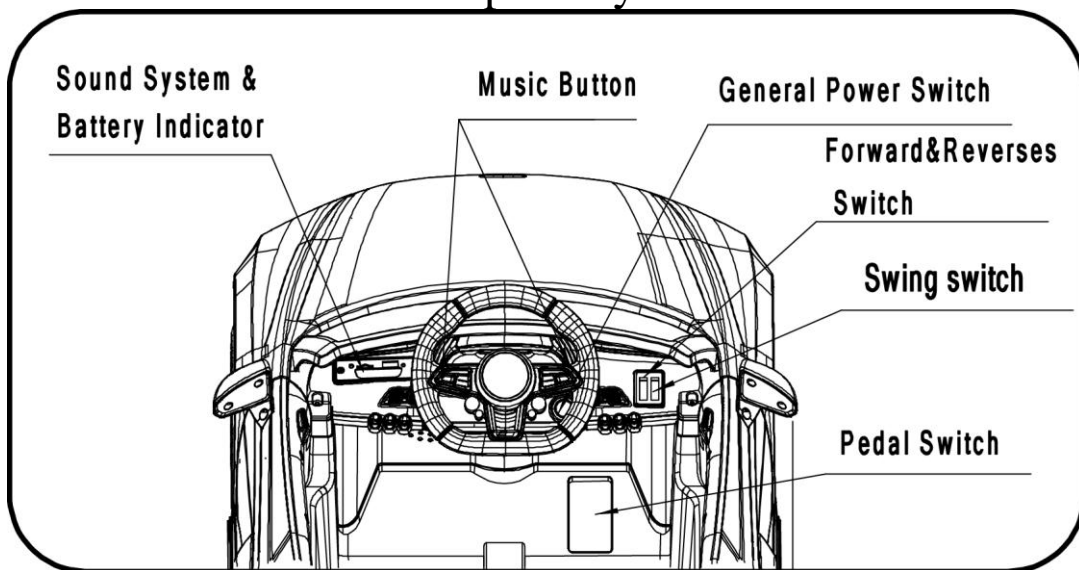

WARNING!

Stop vehicle when changing speed or direction to avoid damage to the gear box and motor. If the gearbox or motor is damaged for whatever reason, it will be deemed physical customer misuse and will void all warranty.

- Turn on the general power switch first and a sound will be emitted.
- Forward
 - Press the "Forward and Reverse switch" to the " ↑ " position.
 - Press the pedal.
 - The vehicle drives forward.
- Stop
 - Remove foot from the accelerator pedal to stop the car.
- Reverse
 - Press the "Forward and Reverse switch" to the " ↓ " position. Press the pedal.
 - The vehicle drives backward.
- Turn on the general power switch and then you can toggle the music options.
- Turn on the general power switch and then turn on the swing switch and the car will swing.

How to use the remote control

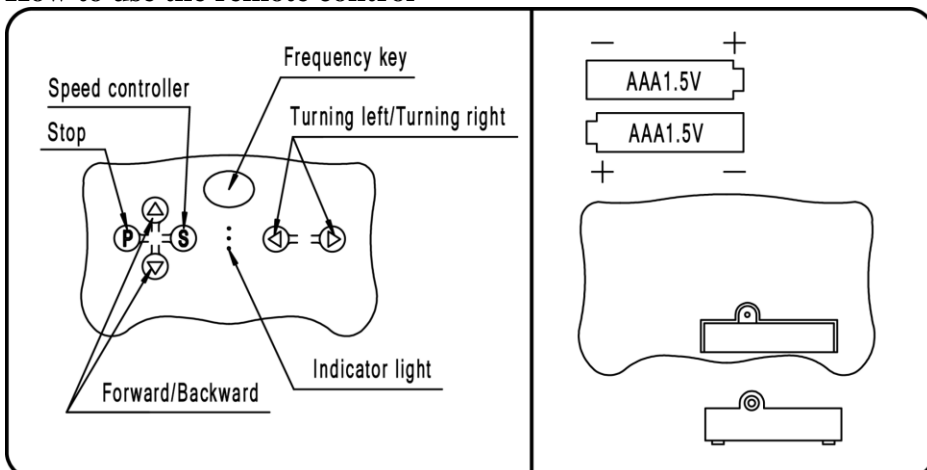

- Turn off the vehicle before setting up the remote control.
- Remove the battery cover of remote control, insert two AAA 1.5V batteries (See above diagram) and the light of remote control will illuminate. Replace the battery cover.
- Hold the "Frequency key" down for 2 to 4 seconds, the indicator light of remote controller will blink.
- Turn on the general power switch.
- Matching the frequency code - Pairs automatically and does not require any buttons to be selected.
- Once the code is matched, there is no need to match it again.
 - When batteries are removed, the remote will need to be paired again, so repeat the previous steps.
- Pushing the left joystick forward which will propel the vehicle forward. Pushing the left joystick back, will propel the vehicle backwards.
- Pushing the right joystick to the left, will turn the vehicle to the left. Pushing the right joystick to the right, the vehicle turn the vehicle to the right.
- "Stop button" stops the vehicle.
- Toggling the "Speed Controller" button will control the vehicle's speed.

How to use the Sound System & Battery Indicator

- Product is equipped with a Storage device (certain models) for the use with a USB drive.

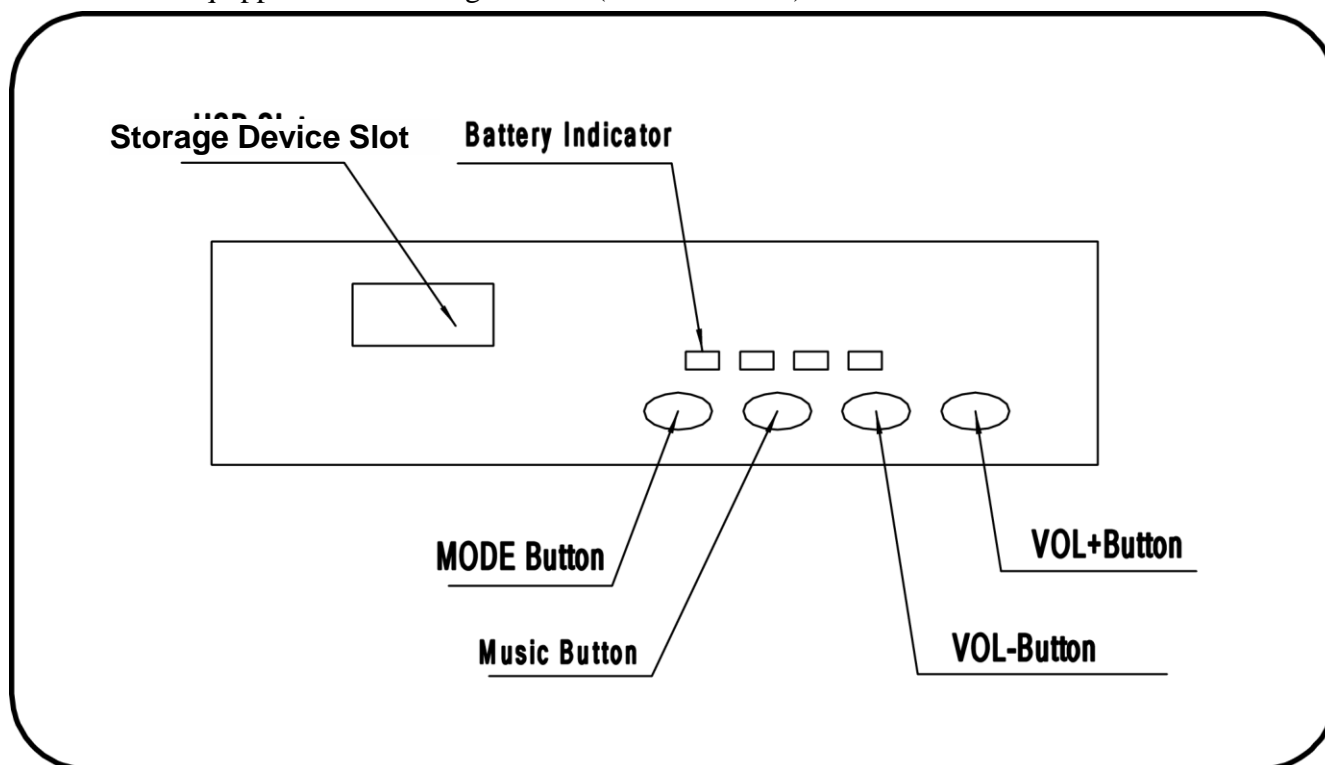

- Holding down "VOL-Button" or "VOL+Button" will adjust the volume
- Quickly pressing "VOL-Button" or "VOL+Button" will switch between music and radio.
- "Music Button" controls the music (i.e., play or pause)

ONLY AN ADULT CAN CHARGE AND RECHARGE THE BATTERY!

- Non-rechargeable batteries are not to be recharged;
- Different type of batteries or new and used batteries are not to be mixed;
- Batteries are to be inserted with the correct polarity;
- Exhausted batteries are to be removed from the toy;
- Supply terminals are not to be short-circuited.
- Rechargeable batteries are only to be charged under adult supervision;
- Rechargeable batteries are to be removed from the toy before being charged;
- The transformers or battery charger used with the toy are to be regularly examined for damage to the cord, plug, enclosure and other parts, and in the event of such damage, they must not be used until that damage had been repaired.

 WARNING!**PREVENT FIRE AND ELECTRIC SHOCK:**

- Use the only rechargeable battery and charger supplied with your vehicle. NEVER substitute the battery or the charger with another brand. Using another battery or charger may cause a fire or explosion.
- Do not use the battery or charger for any other product. Overheating, fire or explosion could occur.
- NEVER modify the electric circuit system. Tampering with the electric system may cause a shock, fire or explosion or may permanently damage the system.
- Do not allow direct contact between battery terminals. Fire or explosion can occur.
- Do not allow any type of liquid on the battery or its components.
- Explosive gasses are created during charging. Do not charge near heat or flammable materials. Charge the battery in a well-ventilated area ONLY.
- NEVER pick up the battery by the wires or charger. Damage can occur to the battery and may cause a fire. Pick up the battery by the case ONLY.
- Charge the battery in a dry area ONLY.
- Do not open the battery. Battery contains lead acid and other materials that are toxic and corrosive.
- Do not open the charger. Exposed wiring and circuitry inside case may cause electric shock. Only adults may handle or charge the battery. NEVER allow child to handle or charge the battery. Battery is heavy and contains lead acid (electrolyte).

WARNING!

PREVENT FIRE AND ELECTRIC SHOCK:

- Do not drop the battery. Permanent damage to the battery could occur or cause serious injury.
- Before charging the battery, check for wear or damage to the battery, charger, its supply cord and the connectors. **DO NOT** charge the battery if any damage to parts has occurred.
- Do not allow the battery to drain completely. Recharge the battery after each use or once a month if not used regularly.
- Do not charge battery upside down.
- Always secure the battery with the bracket. Battery can fall out and injure a child if vehicle tips over.
- A recommendation for adult supervision of young children.
- The toy should be used with caution since skill is required to avoid falls or collisions causing injury to the user or third parties.

- The charging input socket is located below the seat.
- The **POWER SWITCH** must be turned in **OFF** position when charging.
- Before the first use, you should charge the battery for 8-12 hours. Do not recharge the battery for more than 20 hours to avoid overheating the charger.
- When the vehicle begins to run slowly, recharge the battery.
- After each use or once a month minimum recharge time as 8 to 12 hours, no more than 20 hours.
- Battery packed in battery case could be taken out from the car for portable charging.

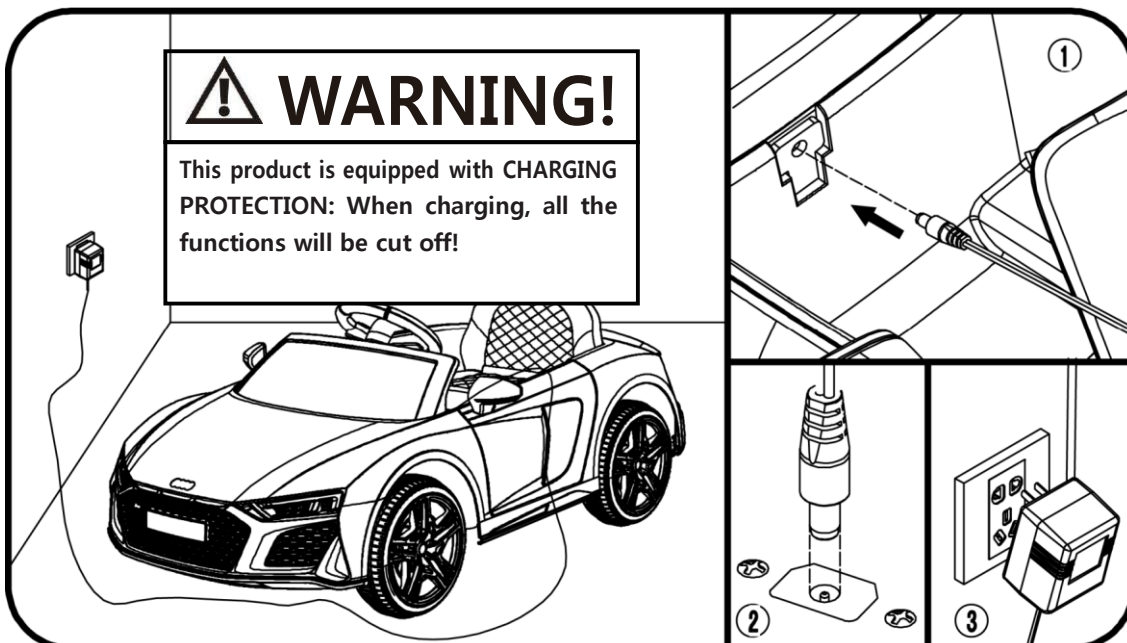

1. Find the charging input socket below the seat;
2. Plug the charger port into the input socket;
3. Plug the charger plug into a wall outlet. The battery will begin charging.

<u>PROBLEM</u>	<u>ASSESSMENT</u>	<u>SOLUTION</u>
Car does not work	Low Power	Recharge battery
	Damage of thermic fuse	Change thermic fuse
	Loss of wheel nut	Install new nut
	Loose battery connector	Check and re-connect the battery
	Dead battery	Replace battery
	Damage of electrical parts	Contact supplier to replace product
	Motor damage	Contact supplier to replace product
Battery cannot be recharged	Loose battery connector	Tighten the connector (ensure the product is switched off before attempting)
	Charger does not connect to battery	Attempt disconnecting and then re-connecting charger
	Damaged charger/adaptor	Contact supplier for new charger
Short operating time	Low battery power	Recharge the battery for up to 10 hours
	Old battery	Replace battery
Noise and heat during charging	Charging process	Normal and safe
Low Speed	Old battery	Replace battery
	Low power	charge battery for up 10 hours
	Overloaded	Reduce the weight to below 30kgs
	Not being operated on suitable ground/environment	Only use this product on flat, hard surface
Noisy gear box	Gearbox has been damaged	Warranty is void, but contact supplier for assistance
	Motor has been damaged	Warranty is void, but contact supplier for assistance
Car shakes when in use	Poor wire connection	Check all the wires when the product is disconnected
	Motor is faulty	Motor may be damaged, contact supplier
No lights and sound when in use	Loose sound/light cable	Check all the wires when the product is disconnected
	Damage to sound and light power board	Contact supplier
Car will not stop when in use	Damage to electrical parts	Contact supplier
Unusual remote control functionality	Remote control batteries are dead	Replace batteries
	Remote control is too far away from the car	Keep a closer distance between remote and car
	Remote control is damaged	Replace remote control
	Receiver board in the car is damaged	Change receiver board
	Radio interference	Change location of where the car is used

The vehicle is equipped with a self-resetting fuse. When the vehicle is overloaded or operated incorrectly; the self-resetting fuse will be cut off for 5-20seconds before becoming operational again. The self-resetting fuse is under the seat (Refer to diagram)

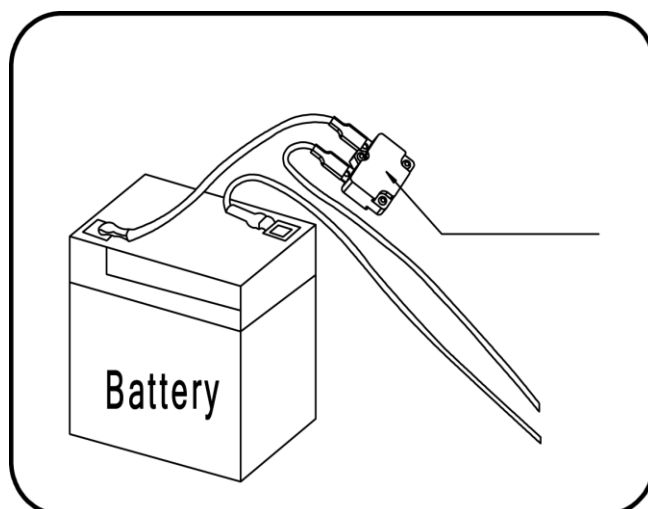

To avoid the fuse being tripped, follow these guidelines:

- DO NOT tow anything behind the vehicle.
- DO NOT drive up steep slopes.
- DO NOT drive into fixed objects, which may cause the wheels to spin, causing the motor to overheat.
- DO NOT drive in very hot weather, components may overheat.
- DO NOT tamper with the electric system. Doing so may create a short circuit, causing the fuse to
- trip.

Maintaining Your Vehicle

- It is the parents/guardians responsibility to inspect the vehicle and all its parts before each use.
- Must regularly examine for potential hazard, such as the battery, charge, cable or cord, plug, screws are fastening enclosure of other parts and that in the event of such damage, the toy must not be until that damage has been properly removed.
- Make sure the plastic parts of the vehicle are not cracked or broken.
- Occasionally use a lightweight oil to lubricate moving parts such as wheels.
- Park the vehicle indoors or cover it with a tarp to protect it from wet weather.
- Keep the vehicle away from sources of heat, such as stoves and heaters. Plastic parts may melt.
- Recharge the battery after each use. Only an adult can handle the battery. Recharge the battery at least once a month when the vehicle Raider is not being used.
- Do not wash the vehicle with a hose. Do not wash the vehicle with soap and water. Do not drive the vehicle in rainy or snowy weather. Water will damage the motor, electric system and battery.
- Clean the vehicle with a soft, dry cloth. To restore shine to plastic parts, use a non-wax furniture polish. Do not use car wax. Do not use abrasive cleaners.
- Do not drive the vehicle in loose dirt, sand or fine gravel which could damage moving parts, motors or the electric system.
- When not using, all the electrical sources should be turn off. Turn off the power switch and disconnect the battery connection.

WARNING: NOT FOLLOWING THE ABOVE MAINTENANCE REQUIREMENTS WILL VOID ALL PRODUCT WARRANTY.

Disposal Of Battery



- Your sealed lead-acid battery must be recycled or disposed of in an environmentally sound manner.
- Do not dispose of your lead-acid battery in a fire. The battery may explode or leak.
- Do not dispose of a lead-acid battery in your regular, household trash. The incineration, land filling or mixing of sealed lead-acid batteries with household trash is prohibited by law.
- Return an exhausted battery to your local approved lead-acid battery recycle, such as a local seller of automotive batteries.
- Contact your local waste management officials for other information regarding the environmentally sound recycling and disposal of lead-acid batteries.
- The battery must be charged only by an adult. Please charge the product before using!
- The toy should not be connected to excessive powers (more than the quantity specified herein), and it should not be operated during charging process.
- Any rechargeable battery must only be charged under adult's supervision.
- Battery charger shall regularly check the wires, plugs, casing and other parts for damage and found damage should stop using and restored.
- Open the battery cover on the remote control, and put two pieces of batteries, paying attention to batteries polarity. Replace the battery cover and lock with screws
- (please replace the battery according to the above steps and should be done by adult) .
- All batteries should be inserted with the correct polarity.
- Non-rechargeable battery should not be charged, please remove any running-off battery from the toy.
- Do not use old and new batteries together, or mix different types of batteries.
- The battery charger used with the toy are to be regularly examined for damage to the cord, plug, enclosure and other parts, and in the event of such damage, they must not be used until that damage had been repaired.

Warranty and Contact Details

Kmate Pty Ltd provides a 12 month warranty for this product when used for domestic purposes. This product is not intended for commercial use and any such use will void all warranty.

The benefits of this warranty are provided in addition to other rights and remedies you may have under a law in relation to the goods and services to which this warranty relates. Our goods come with guarantees that cannot be excluded under the Australian Consumer Law. You are entitled to a replacement or refund for a major failure and for compensation for any other reasonably foreseeable loss or damage. You are also entitled to have goods repaired or replaced if the goods fail to be of acceptable quality and the failure does not amount to a major failure.

Before making a claim under warranty, please refer to your user/installation manual to ensure that you have followed correct operating procedures of your product and refer to the trouble shooting section (if such exists) to assist solving any problems.

The warranty period begins from the day of purchase.
Your proof of purchase must be produced before assistance will be provided.

Where the Product is replaced pursuant to this Warranty, the replacement Product will be subject to the warranty terms and warranty commencement date of the original product.

This warranty is only valid if the product is operated and maintained in accordance with the manufacturer's instructions.

Damage to property including but not limited to furniture, carpets, walls, ceilings or any other event either directly or indirectly are excluded from warranty as well as any losses or expenses incurred by you in relation to the product or making a claim under this warranty including without limitation any costs associated with installation, reinstallation or transporting the product.

Light globes, remote controls, batteries, filters or similar perishable parts are not covered under this warranty.

A claim may be refused if the defective claim has arisen for reasons other than a manufacturers fault or defective parts or workmanship. Circumstances in which a warranty claim may be declined include, but are not limited to the following:

- Normal wear and tear;
- Misuse or abuse, including failure to properly maintain or service;
- Damage caused by improper or incorrect installation, force-majeure, electrical surges, lightning, power grid fluctuations, water or by connection to alternative power supply sources (such as solar inverters etc), are not eligible for warranty repair;
- Damage to product caused by overcharging batteries or overloading car;
- Insect or vermin infestation;
- Failure to clean or improper cleaning and/or operation of the product;
- If the car exhibits any signs of physical impact irrespective if the fault claimed is with any internal components;
- If the product is modified without authorisation from Kmate Pty Ltd in writing; and
- Batteries over 6 months old from the date noted on the customer's invoice.

Contact Details

Kmate Pty Ltd
PO Box 133, Braeside VIC 3195
Email: warranty@klika.com.au
Phone: 03 9790 0055