

## CHILDREN'S BATTERY OPERATED RIDE ON CAR

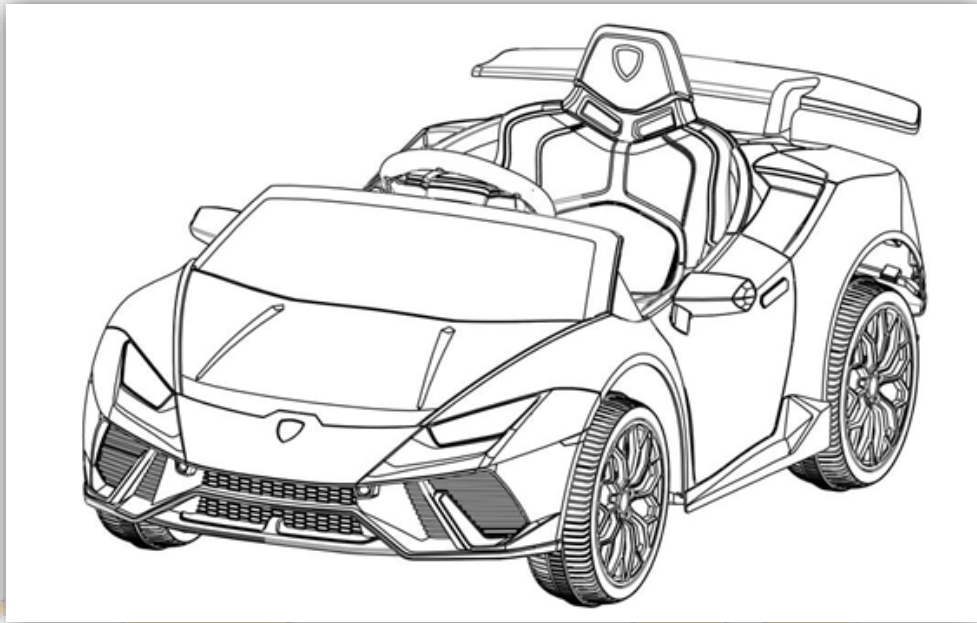

ILLUSTRATION USED AS A REFERENCE ONLY. INSTRUCTIONS APPLY TO VARIOUS MODELS.

BATTERY MAY BE PARTIALLY CHARGED ON DELIVERY. IT IS CRITICAL FOR THE BATTERY TO BE FULLY CHARGED PRIOR TO USE (8-12 HOURS)

### Important information

Important	Warning!
Age: 3 years + Maximum user weight: 30 Kg	For domestic use only Not to be used in traffic Adult assembly required

Battery	12V
Motor	12V
Charger	Output DC 12V
Max Load	30 KG
Speed	3 - 5 km / hr
Age	3+ years
Assemble time	45 minutes approx 2 person assembly

Adult supervision required at all times

This vehicle does not have brakes or braking capacity

Small parts may pose choking hazard - keep out of reach of children

Keep away from moving parts

Store indoors or protected from weather and sun

**FAILURE TO FOLLOW INSTRUCTIONS MAY RESULT IN INJURY, PROPERTY DAMAGE AND WILL VOID WARRANTY.**



**IMPORTANT: Please read the following instructions in full before assembly or use**

These instructions contain important information which will help you get the best from your product and ensure safe and correct assembly, use and maintenance.

**CAUTION:**











- **Product is to be used strictly under appropriate adult supervision. Children are not to be left unsupervised with the product.**
- **Product is suitable for children aged 3+ and up to a maximum weight capacity of 30kgs. Overloading the car may result in damage to integral parts such as motor and gearbox and will void all warranty.**
- **Supplied seatbelt is a decoration only and is only intended to instil a sense of practicing safety in children. It does not provide any substantial protection and not to be relied on for the purpose of safety.**
- Please ensure an adult visually inspects the product prior to each use, for any signs of wear and tear and damage. If any abnormal damage or cracks are exhibited, please cease using the toy immediately, as it may be unsafe.
- The product should not be used on public streets or roads, near moving vehicles, steep inclines/hills or near pools or water, or any other dangerous environment.
- Do not expose the product to liquids or harsh detergents. Clean only with a soft, clean cloth to avoid causing damage to the surface of the product.
- Product is designed to be used on a suitable, flat, debris free surface. Please do not use the product on sand, gravel, dirt, grass and uneven or rough surfaces.
- Using the product indoors may result in damage to flooring.
- Product is equipped with a remote control which is to be used only by responsible adults.
- Replace batteries in the remote control if the operating range is reduced.
- Only switch between reverse and forward modes when the car is stationary. Don't suddenly switch between forward and reverse directions whilst the car is moving, as it will likely damage the product.
- This product is equipped with motors which can produce sparks. Please keep away from flammable products.
- Supplied packaging is not a toy and is to be disposed of thoughtfully.
- Adult supervisors are expected to read the supplied instructions in their entirety and provide correct guidance to children. Instructions should cover such basic elements as:
  - Correctly steering, starting and stopping the toy car;
  - Only a single rider is to use the product at any given time;
  - Shoes to be worn at all times;
  - All parts of users' bodies and their clothing to be kept away from moving parts failing which they run a risk of friction burns/and or risk of entrapment.
- Product is equipped with an overheat/overload function. This function is self-resetting to avoid overheating and damage to the product should the product be overloaded. Once the fuse has been tripped, it will auto-reset itself after approximately 10 seconds which will then allow the toy car to resume normal operations. To avoid repeatedly tripping this function do not overload the toy and be within the weight limit and do not drive the toy car in an inappropriate manner and conditions.

## **CHARGING THE BATTERY**

- All charging and re-charging must be carried out by an adult.
- Do not attempt to use the product while it is being charged.
- Charging should be carried out under cover and in a well-ventilated area.
- Always ensure the charger is switched off before connecting it to the product/battery.
- Always ensure the charger is plugged into a wall outlet. Do not use an extension.
- Do not charge near sources of potential sparks, fires or flames or where flammable gases, liquids and materials are stored.
- During charging the battery and the charger may get hot.
- Only charge the battery for a maximum time of 8 - 12 hours.
- Do not leave the charger plugged into an outlet or connected to the product/battery once charging is completed.
- Never attempt to recharge a fully charged or partially used battery for an extra boost.
- Do not over-charge as it will significantly shorten battery life.
- Always ensure that once the battery becomes discharged/flat that you re-charge for the recommended time. Failing to do so will significantly shorten battery life.
- Charging the product below 4oC (40oF) or above 40oC (104oF) will decrease the battery life significantly.
- V.R.L.A. batteries are heavy and contain lead & acid. They are dangerous if improperly handled.
- Only use the charger supplied with the product. The use of other chargers may cause damage to the battery and/or cause explosion.
- Battery chargers used with the product are to be regularly examined for damage to the cord, plug, enclosure and other parts, and in the event of such damage, they must not be used until the damage has been repaired.
- Only use the battery supplied with this product. Use of other batteries may cause damage to the motor, charger and wiring, which could lead to fire and/or explosion, and void warranty.
- Dead batteries are to be removed from the toy and disposed off responsibly.
- Always ensure that you connect the battery with the correct polarity.
- Never short-circuit the terminals of the battery, or any subsequent wiring.
- Never bypass or bridge a broken/blown fuse or circuit breaker and always replace with the same type/value and model.

**BATTERY CYCLE WILL DEplete OVER TIME AND IS REGARDED AS A CONSUMABLE PART COVERED BY 6 MONTHS WARRANTY FROM THE DATE ON INVOICE.**

**PARTS LIST**

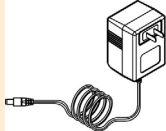
Part #	Part Name	Picture	Qty	Comment	Part #	Part Name	Picture	Qty	Comment
1	Ø10 Washer		6		2	M10 Nut		4	
A	Wheel		4		B	Wind shield		1	
C	Wheel cover		4		D	Mirrors		1	1 set of 2
E	Seat		1		F	Steering wheel		1	
G	Tail stock		1		H	Remote control		1	
	M10 Wrench		1			Charger		1	

### FRONT WHEEL ASSEMBLY

1. Put the gasket, wheel, gasket and nut into the front axle on each side.
2. Fix the nut with the M10 wrench.
3. Attach the wheel cover to the wheel.

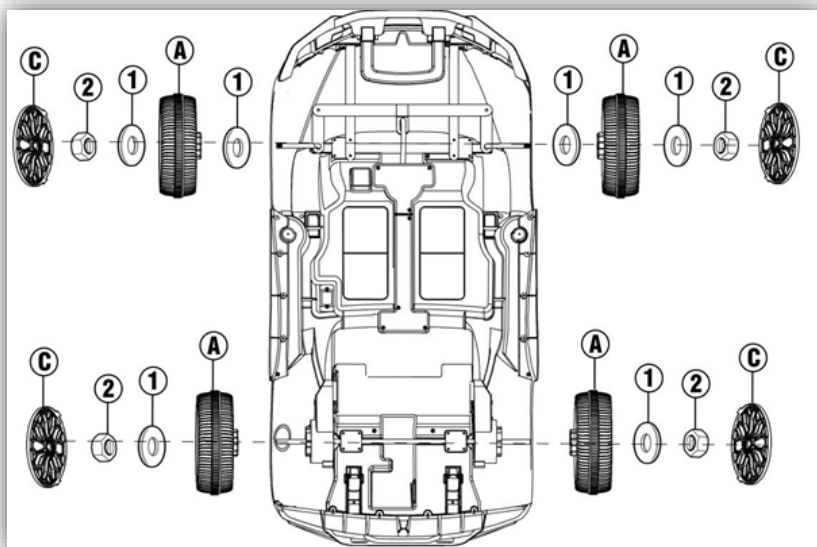

### REAR WHEEL ASSEMBLY

1. Place the wheel, gasket and nut on the rear axle on each side.
2. Fix the nut with the M10 wrench.
3. Attach the wheel cover to the wheel.

### CONNECT THE POWER CORD

1. Turn the vehicle upside down taking care not to damage any parts.
2. Find the main power cord under the seat.
3. Insert the plug of the power cord into the corresponding jack of the receiver.

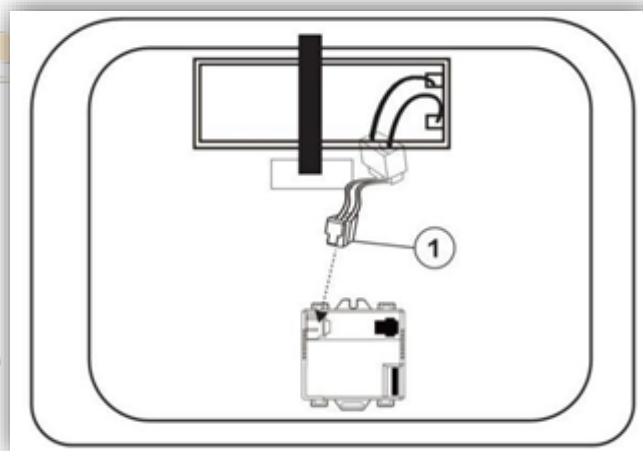

### STEERING WHEEL

1. Remove the nut and bolt from the steering wheel.
2. Connect the wires from the steering column to the wires on the steering wheel.
3. Insert the steering wheel over the steering column, fasten and secure with nut and bolt.

### FIX THE TAILSTOCK

1. Install the tailstock on to the body as shown below.

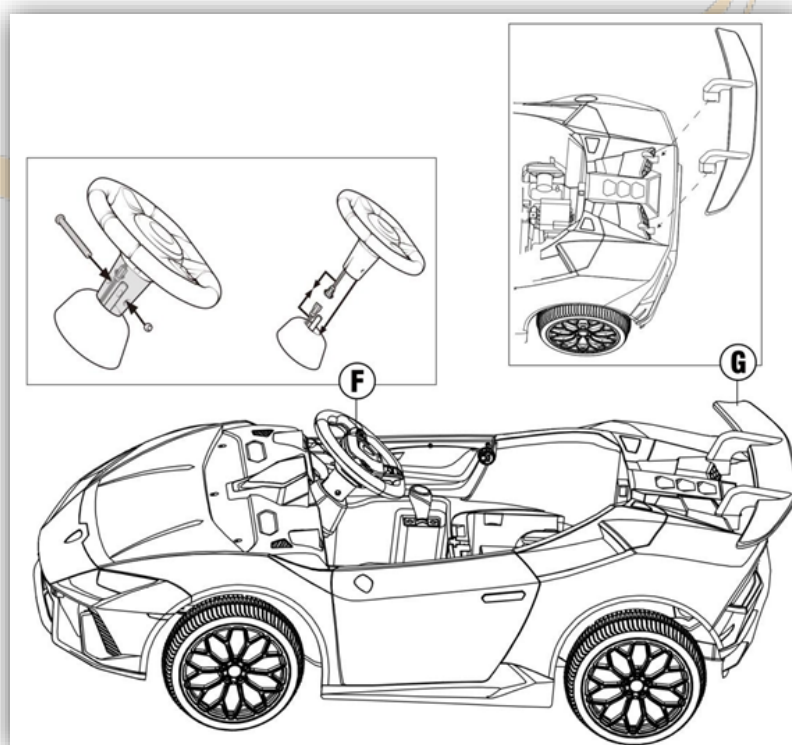

### ATTACH THE WINDSHIELD

1. Fit the windshield into the corresponding slots on the body as shown below.

### ATTACH MIRRORS.

1. Insert the mirror into the slots on the car as pictured below, each mirror is labelled "left" and "right".

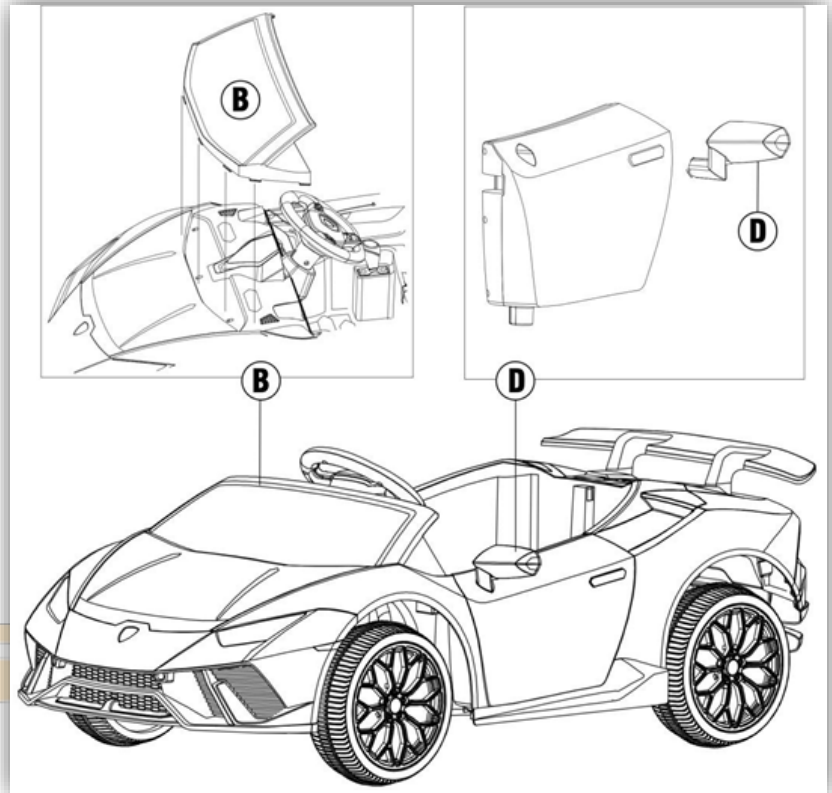

### INSTALL THE SEAT

1. Insert the seat buckle into the slot in the vehicle.
2. Press the seat button to secure it.

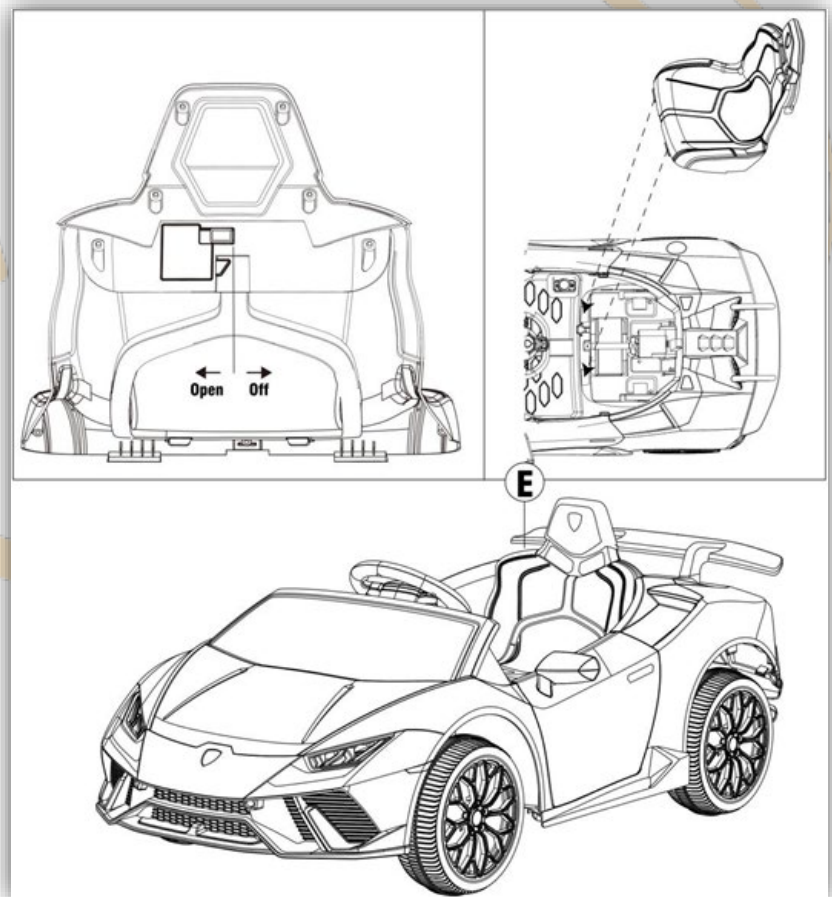

## HOW TO USE YOUR VEHICLE

1. Pedal.
  - When you apply pressure to the pedal, the car will move forward.
  - Remove pressure from the pedal and the car will slow down.
2. Shift switch.
  - Changes direction of the car, either forward or backwards.
3. Horn button.
  - Press to honk the horn.
4. Control board (pictured).
5. USB
6. Power display: shows battery power.
7. Charging socket.
8. Light switch.
  - Press to play last song.
  - Press and hold to decrease volume.
9. Last song and volume decrease.
10. Music button.
  - Press to play next song.
  - Press and hold to increase volume.
11. Next song and volume increase.
12. Power button.
  - Press and hold for 3 seconds to turn vehicle on or off.
13. High speed.
  - Press to change car to high speed mode.
14. Low speed.
  - Press to change car to low speed mode.
15. Wireless technology.
  - Connect you mobile phone and wireless device to play music from your phone in the vehicle.
16. Pause button.
  - Press to pause music.

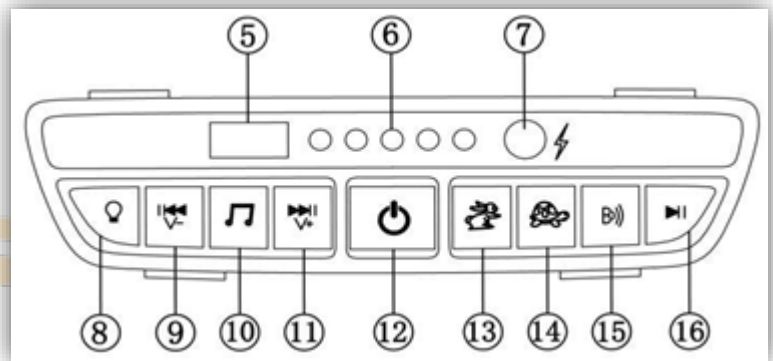

## HOW TO USE YOUR REMOTE CONTROL

When remote control is in use, the foot pedal will not work.

Take out the remote control, open the battery compartment on the back of the remote control and add two AAA LRO3 alkaline batteries, ensuring you insert them the correct way.

When the alignment light and speed indicator light up, it indicates that the batteries have been installed correctly.

Long press on the frequency key(M) 2-4 seconds, Low speed LED light flashing. Turn on the power of the car, Low speed LED light keep flashing to long lighting, then frequency bind succeed. If the frequency bind failed (Low speed LED light flashing) , remove the battery and repeat steps

P: Press to brake.

S: Speed: press to change speed (low, middle and high speed).

△Forward ▽backward.

◁ Turn left.

▷ Turn right.

Brake button: Press it to stop moving; press it again to move.

Speed selection key and speed indication: used to select speed of the car. Press the key once to switch the speed once. 3 speeds are cyclically switched, and the switching sequence is: low-medium-high. The speed indicator is arranged from top to bottom on the remote control: high-speed lamp, medium-speed lamp, low-speed lamp; when switching to one speed, the corresponding indicator lamp will light up. Note: The speed only changes when moving forward

Forward/backward keys: used for forward and backward movement control. When one of the keys is pressed, the moving speed will slowly increase to reach the set speed level.

Left turn/right turn key: used for left and right direction control.

**NOTE: WITHOUT OPERATION FOR 10 SECONDS, REMOTE WILL GO INTO POWER SAVING MODE**



### **ONLY AN ADULT CAN CHARGE AND RECHARGE THE BATTERY**

- Non-rechargeable batteries are not to be recharged;
- Different type of batteries or new and used batteries are not to be mixed;
- Batteries are to be inserted with the correct polarity;
- Exhausted batteries are to be removed from the toy;
- Supply terminals are not to be short-circuited.
- Rechargeable batteries are only to be charged under adult supervision;
- Rechargeable batteries are to be removed from the toy before being charged;
- The transformers or battery charger used with the toy are to be regularly examined for damage to the cord, plug, enclosure and other parts, and in the event of such damage, they must not be used until that damage had been repaired.

## **! WARNING!**

- **PREVENT FIRE AND ELECTRIC SHOCK:**
- Use only rechargeable battery and charger supplied with your vehicle. NEVER substitute the battery or the charger with another brand. Using another battery or charger may cause a fire or explosion.
- Do not use the battery or charger for any other product. Overheating, fire or explosion could occur.
- NEVER modify the electric circuit system. Tampering with the electric system may cause a shock, fire or explosion or may permanently damage the system.
- Do not allow direct contact between battery terminals. Fire or explosion can occur.
- Do not allow any type of liquid on the battery or its components.
- Explosive gasses are created during charging. Do not charge near heat or flammable materials. Charge the battery in a well-ventilated area ONLY.
- NEVER pick up the battery by the wires or charger. Damage can occur to the battery and may cause a fire. Pick up the battery by the case ONLY.
- Charge the battery in a dry area ONLY.
- Do not open the battery. Battery contains lead acid and other materials that are toxic and corrosive.
- Do not open the charger. Exposed wiring and circuitry inside case may cause electric shock. Only adults may handle or charge the battery. NEVER allow child to handle or charge the battery. Battery is heavy and contains lead acid (electrolyte).
- Do not drop the battery. Permanent damage to the battery could occur or cause serious injury.
- Before charging the battery, check for wear or damage to the battery, charger, its supply cord and the connectors. DO NOT charge the battery if any damage to parts has occurred.
- Do not allow the battery to drain completely. Recharge the battery after each use or once a month if not used regularly.
- Do not charge battery upside down.
- Always secure the battery with the bracket. Battery can fall out and injure a child if vehicle tips over.
- Adult supervision of young children is recommended.

- The toy should be used with caution. Skill is required to avoid falls or collisions causing injury to the user or third parties.
- The POWER SWITCH must be turned in OFF position when charging.
- Before the first use, you should charge the battery for 4-6 hours. Do not recharge the battery for more than 10 hours to avoid overheating the charger.
- When the vehicle begins to run slowly, recharge the battery.
- After each use or once a month minimum recharge time as 8 to 12 hours, less than 20 hours at most.
- Your ride-on with a Digital voltmeter, if equipped, will measure the level of voltage allowing you to see how much power is remaining in the battery.

**THIS PRODUCT IS FITTED WITH CHARGING PROTECTION: WHEN CHARGING, ALL FUNCTIONS WILL BE CUT OFF! ONLY AN ADULT CAN CHARGE AND RECHARGE THE BATTERY**

## **WARNING!**





### PREVENT INJURIES AND DEATHS:

- **NEVER LEAVE CHILD UNATTENDED. DIRECT ADULT SUPERVISION IS REQUIRED.**
  - Always keep child in view when child is in vehicle.
- This toy should be used with caution since skill is required to avoid falls or collisions causing injury to the user or third parties.
- Protective equipment should be worn.
- Never use in roadways, near cars, on or near steep inclines or steps, swimming pools or other bodies of water.
- Always wear shoes.
- Always sit on the seat.
- Not to be used in traffic.
- This toy is not suitable for children under 3 years of age
- Maximum user weight is 30 kgs.
- This toy has no brake.

### RULES FOR SAFE RIDING

- Keep Children within Safe Riding Areas:
- Never use on a roadway, near motor vehicles, lawns, on or near steep inclines or steps, swimming pools or bodies of water;
- Use the toy only on flat surfaces.
- Never use in the dark due to unexpected obstacles causing injury the user, property and or third parties. Operate the vehicle only in the daytime or a well-lit area.
- Do not change the circuit or add other electric parts.
- Inspect wires and connections of the vehicle periodically.
- Do not let any child touch the wheels or be near them when the car is moving .



- This vehicle has adjustable play seat belts. Please instruct children how to use a seat belt.
- Do not tow anything   behind the vehicle.
- Do not drive into fixed objects which may cause the wheels to spin, causing the motor to   overheats.
- Do not drive in very hot weather, components may overheat.
- Do not tamper with the electric system. Doing so may create a short circuit, causing the fuse to trip.
- Make sure the user knows how to steer, how to start and stop the vehicle and knows the rules for safe driving. The vehicle can be driven at a maximum of 2.5 - 5 km/h.

### **BATTERY REPLACEMENT AND FUSE**

The battery features a thermal fuse with a reset fuse that will automatically trip and cut all power to the vehicle if the motor, electric system or battery is overloaded. The fuse will reset and power will be restored after the unit is turned OFF for 20 seconds and then turned ON again. If the thermal fuse trips repeatedly during normal use, the vehicle may need repair. *Contact your distributor.*

To avoid losing power, follow these guidelines:

- Do not overload the vehicle.
- Do not tow anything behind the vehicle.
- Do not drive up steep slopes.
- Do not drive into fixed objects, which may cause the wheels to spin, causing the motor to overheat.
- Do not drive in very hot weather, components may overheat.
- Do not allow water or other liquids to come in contact with the battery or other electric components.
- Do not tamper with the electric system. Doing so may create a short, causing the fuse to trip.

### **BATTERY REPLACEMENT**

The battery will eventually lose the ability to hold a charge. Depending on the amount of use, and varying conditions, the battery should operate for one to three years. Follow these steps to replace and dispose the battery:

1. Remove the car seat.
2. Disconnect the battery connectors.
3. Remove the battery bracket.
4. Remove the battery cover.
5. Carefully lift the battery.
6. Depending on the condition of the battery (i.e. leakage) you may choose to wear protective gloves before removal.
7. Do not lift the battery by its connectors or cables.
8. Place the dead battery in a plastic bag.
9. Replace the battery and reconnect the connectors.
10. Replace the metal battery bracket.
11. Replace the seat.

## DISPOSAL OF BATTERY

- Your sealed lead-acid battery must be recycled or disposed of in an environmentally sound manner.
- Do not dispose of your lead-acid battery in a fire. The battery may explode or leak.
- Do not dispose of a lead-acid battery in your regular, household trash. The incineration, land filling or mixing of sealed lead-acid batteries with household trash is prohibited by law.
- Return an exhausted battery to your local approved lead-acid battery recycle, such as a local seller of automotive batteries.
- Contact your local waste management officials for other information regarding the environmentally sound recycling and disposal of lead-acid batteries.
- The battery must be charged only by an adult. Please charge the product before using!
- The toy should not be connected to excessive powers (more than the quantity specified herein), and it should not be operated during charging process.
- Any rechargeable battery must only be charged under adult's supervision.
- Battery charger shall regularly check the wires, plugs, casing and other parts for damage and found damage should stop using and restored.
- Open the battery cover on the remote control, and put two pieces of batteries, paying attention to batteries polarity. Replace the battery cover and lock with screws
- (please replace the battery according to the above steps and should be done by adult) .
- All batteries should be inserted with the correct polarity.
- Non-rechargeable battery should not be charged, please remove any running-off battery from the toy.
- Do not use old and new batteries together, or mix different types of batteries.
- The battery charger used with the toy are to be regularly examined for damage to the cord, plug, enclosure and other parts, and in the event of such damage, they must not be used until that damage had been repaired.

**TROUBLE SHOOTING**

<b>PROBLEM</b>	<b>POSSIBLE CAUSE</b>	<b>SOLUTION</b>
<b>Vehicle does not run</b>	Low battery	Fully charge the battery
	Electrical protection	Stop use for several minutes and restart
	Switch not in the correct position	Put switch in the correct position
	Battery connectors disconnected	Plug in battery connectors
<b>Battery does not recharge</b>	Battery connectors are not connected	Plug in battery connectors
	Charge not connected to socket or outlet	Completely plug in the charger
<b>Battery does not last</b>	Battery does not have a full charge	Fully charge the battery
<b>Slow speed</b>	Low battery	Fully charge the battery
	Overloaded vehicle	Reduce the weight in the vehicle
	Uneven or sloped road	Drive on flat surfaces only
<b>Difficult shifting from forward to reverse or vice-versa</b>	Attempting to shift while the vehicle is motion	Only shift when the vehicle is at a stop
<b>Vehicle shakes while driving</b>	Loose connection to motor	Ensure the motor is properly connected to the battery
<b>Forward and reverse switch is flipped</b>	Gearbox installed incorrectly	Ensure the L gear box is on the left and the R gear box is on the right
<b>Charger feels warm when recharging</b>	Nil	This is normal and not a cause for concern



## **MAINTAINING YOUR TOY VEHICLE**

- It is the parents/guardians responsibility to inspect the vehicle and all its parts before each use.
- Must regularly examine for potential hazard, such as the battery, charge, cable or cord, plug, screws are fastening enclosure of other parts and that in the event of such damage, the toy must not be until that damage has been properly removed.
- Make sure the plastic parts of the vehicle are not cracked or broken.
- Occasionally use a lightweight oil to lubricate moving parts such as wheels.
- Park the vehicle indoors or cover it with a tarp to protect it from wet weather.
- Keep the vehicle away from sources of heat, such as stoves and heaters. Plastic parts may melt.
- Recharge the battery after each use. Only an adult can handle the battery. Recharge the battery at least once a month when the vehicle Raider is not being used.
- Do not wash the vehicle with a hose. Do not wash the vehicle with soap and water. Do not drive the vehicle in rainy or snowy weather. Water will damage the motor, electric system and battery.
- Clean the vehicle with a soft, dry cloth. To restore shine to plastic parts, use a non-wax furniture polish. Do not use car wax. Do not use abrasive cleaners.
- Do not drive the vehicle in loose dirt, sand or fine gravel which could damage moving parts, motors or the electric system.
- When not using, all the electrical sources should be turn off. Turn off the power switch and disconnect the battery connection.

**WARNING: NOT FOLLOWING THE ABOVE MAINTENANCE REQUIREMENTS WILL VOID ALL PRODUCT WARRANTY.**

**KAHUNA**

## **WARRANTY AND CONTACT DETAILS**

Kmate Pty Ltd provides a 12 month warranty for this product when used for domestic purposes. This product is not intended for commercial use and any such use will void all warranty.

The benefits of this warranty are provided in addition to other rights and remedies you may have under a law in relation to the goods and services to which this warranty relates. Our goods come with guarantees that cannot be excluded under the Australian Consumer Law. You are entitled to a replacement or refund for a major failure and for compensation for any other reasonably foreseeable loss or damage. You are also entitled to have goods repaired or replaced if the goods fail to be of acceptable quality and the failure does not amount to a major failure.

Before making a claim under warranty, please refer to your user/installation manual to ensure that you have followed correct operating procedures of your product and refer to the trouble shooting section (if such exists) to assist solving any problems.

The warranty period begins from the day of purchase.

Your proof of purchase must be produced before assistance will be provided.

Where the Product is replaced pursuant to this Warranty, the replacement Product will be subject to the warranty terms and warranty commencement date of the original product.

This warranty is only valid if the product is operated and maintained in accordance with the manufacturer's instructions.

Damage to property including but not limited to furniture, carpets, walls, ceilings or any other event either directly or indirectly are excluded from warranty as well as any losses or expenses incurred by you in relation to the product or making a claim under this warranty including without limitation any costs associated with installation, reinstallation or transporting the product.

Light globes, remote controls, batteries, filters or similar perishable parts are not covered under this warranty.

A claim may be refused if the defective claim has arisen for reasons other than a manufacturer's fault or defective parts or workmanship. Circumstances in which a warranty claim may be declined include, but are not limited to the following:

- Normal wear and tear;
- Misuse or abuse, including failure to properly maintain or service;
- Damage caused by improper or incorrect installation, force-majeure, electrical surges, lightning, power grid fluctuations, water or by connection to alternative power supply sources (such as solar inverters etc), are not eligible for warranty repair;
- Damage to product caused by overcharging batteries or overloading car;
- Insect or vermin infestation;
- Failure to clean or improper cleaning and/or operation of the product;
- If the car exhibits any signs of physical impact irrespective if the fault claimed is with any internal components;
- If the product is modified without authorisation from Kmate Pty Ltd in writing; and
- Batteries over 6 months old from the date noted on the customer's invoice.

### **Contact Details**

Kmate Pty Ltd

PO Box 133, Braeside VIC 3195

Email: [warranty@klika.com.au](mailto:warranty@klika.com.au)

Phone: 03 9790 0055